

3

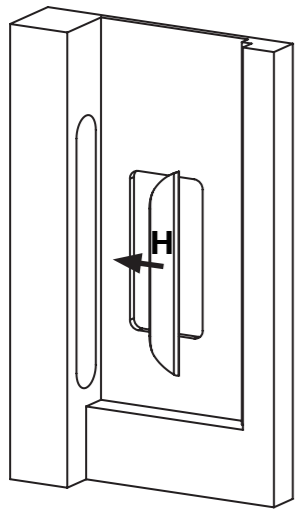

4

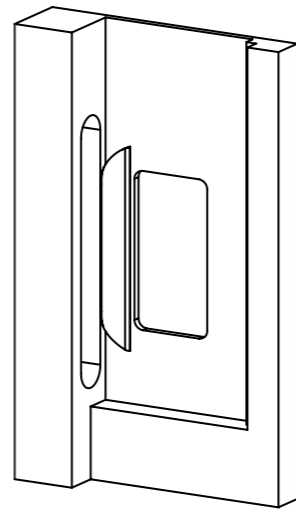

5

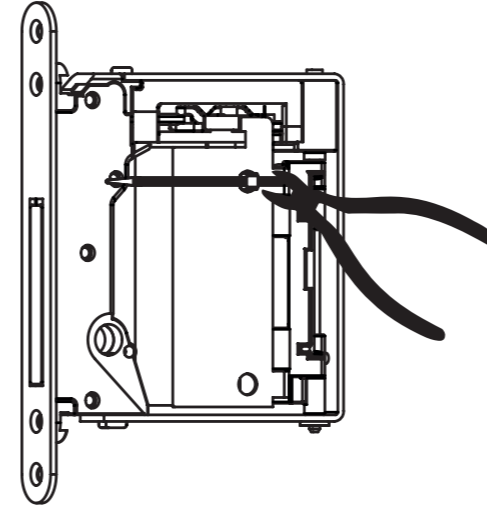

10

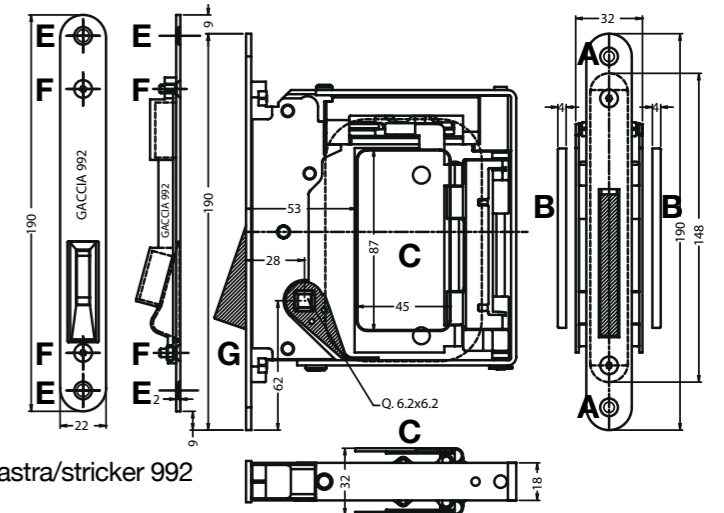

contropiastra/stricker 992

6

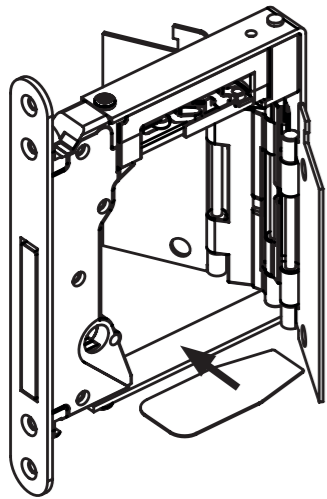

7

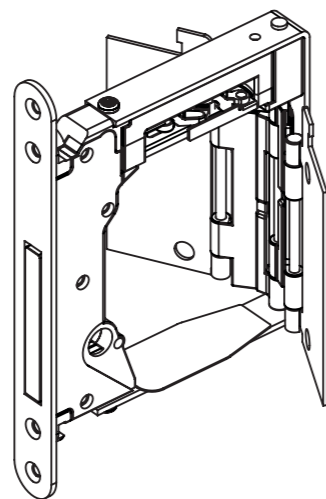

8

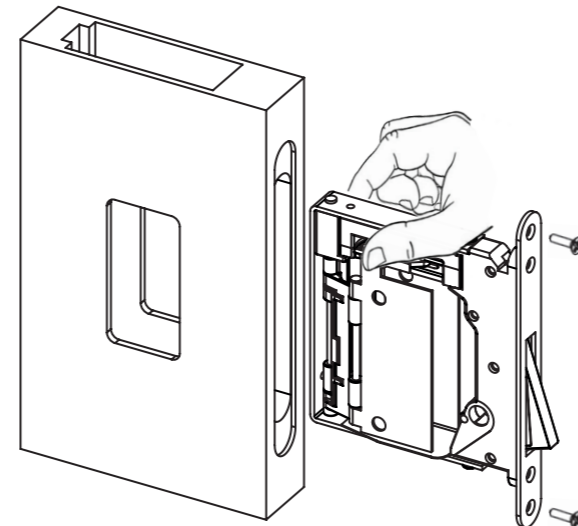

9

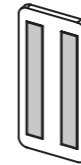

11

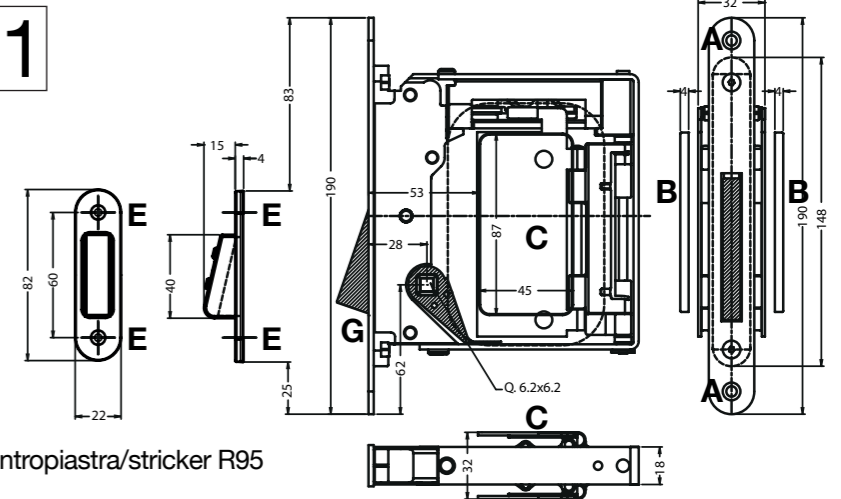

contropiastra/stricker R95



B no-ha Collection

B no-ha *mini* lock

ASSEMBLING INSTRUCTIONS

ATTENTION THE B no-ha *mini* LOCK CAN BE FITTED ON A TRADITIONAL DOOR, IT NEEDS A PARTICULAR MILLING IN ORDER TO CREATE THE SPACE FOR THE DEVICE MECHANISM (picture n.1 and 2).

ASSEMBLING PROCEDURE

- Apply two finger-rest **H** **inside the cavity** (picture n. 3 and 4) (use bi-adhesive tape included in the kit)
- Remove the band which blocks the 2 sides (picture n. 5)
- Apply the frame cover (picture n. 6 and 7)
- Insert the lock holding the 2 sides tight
Fix it with the 2 screws **A** on the front plate (picture n. 8)
- Put bi-adhesive tape (picture n. 9) on the back of plate-covers **B** not included in this kit (picture n.10 and 11)
- Stick the first plate-cover on board **C** of plate keeping pressed the other plate on opposite side. Repeat operation for the second plate-cover
- Verify the correct lock working as follows:
 - a) Take the oscillating latch **G** out of frontal by pressing its upper side
 - b) Engage the plate-cover **B**. The latch **G** must return
 - c) Put the striker 992 or R95 opposite to the front plate. The oscillating latch **G** must come out
- Fix the striker on the frame with the screws **E** (not included)
- Check the door closing and eventually do the necessary regulations on striker acting on screws **F**

Bonaiti
SERRATURE
tecnici@bonaiti.it



1

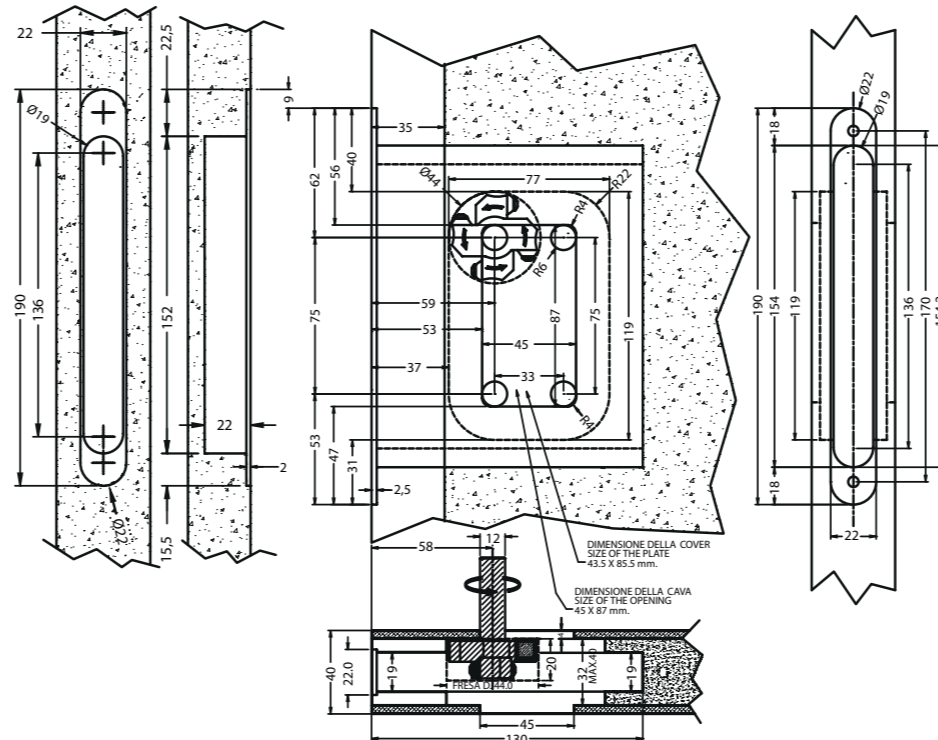

2

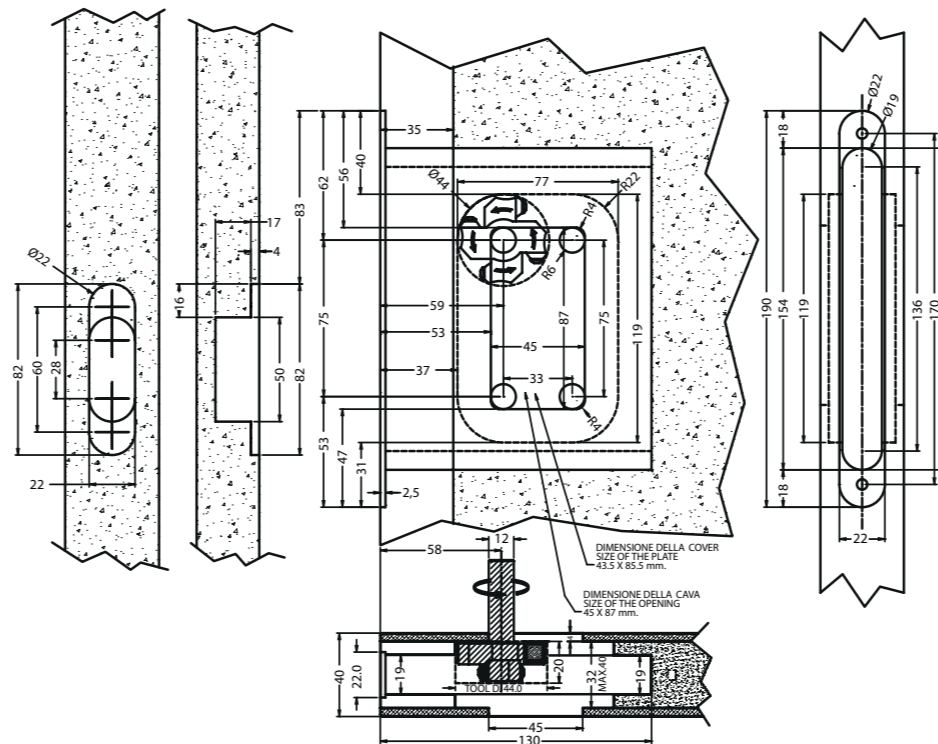

Collezione B no-ha

Serratura B no-ha *mini*

ISTRUZIONI DI MONTAGGIO

ATTENZIONE LA SERRATURA B no-ha *mini* PUO' ESSERE INSTALLATA SU UN PANNELLO TRADIZIONALE, NECESSITA PERO' DI UNA FRESATURA PARTICOLARE CHE ACCOLGA IL MECCANISMO DI FUNZIONAMENTO (vedi dis. 1 e 2).

PROCEDURA DI MONTAGGIO

- Applicare i 2 appoggia-dita **H** all'**interno della cava** (dis. 3 e 4) (utilizzando i biadesivi in dotazione)
- Togliere la fascetta che blocca i 2 laterali (dis. 5)
- Applicare i copri-telaio (dis. 6 e 7)
- Inserire la serratura tenendo stretti i 2 laterali
Fissarla con le 2 viti **A** sul frontale (dis. 8)
- Applicare del nastro biadesivo (dis. 9) sul retro delle cover **B** non incluse nel kit (dis.10 e 11)
- Incollare la cover alla piastra **C** tenendo premuto il pulsante sul lato opposto. Ripetere l'operazione per la seconda cover
- Verificare il corretto funzionamento della serratura nel seguente modo:
 - a) Estrarre l'oscillante **G** dal frontale premendo la parte superiore dello stesso
 - b) Azionare la cover **B**. L'oscillante **G** deve rientrare
 - c) Posizionare la contropiastra 992 o R95 davanti al frontale. L'oscillante **G** deve uscire
- Fissare la contropiastra con le apposite viti **E** (non incluse)
- Provare la chiusura della porta ed effettuare eventuali regolazioni sulla contropiastra con le viti **F**

Bonaiti
SERRATURE
tecnici@bonaiti.it