

6 5 4 3 2 1

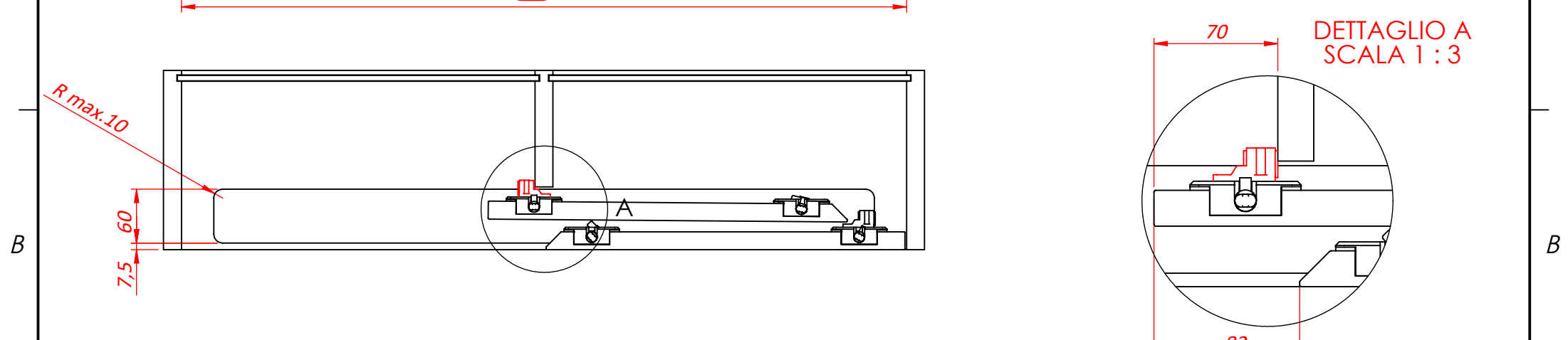
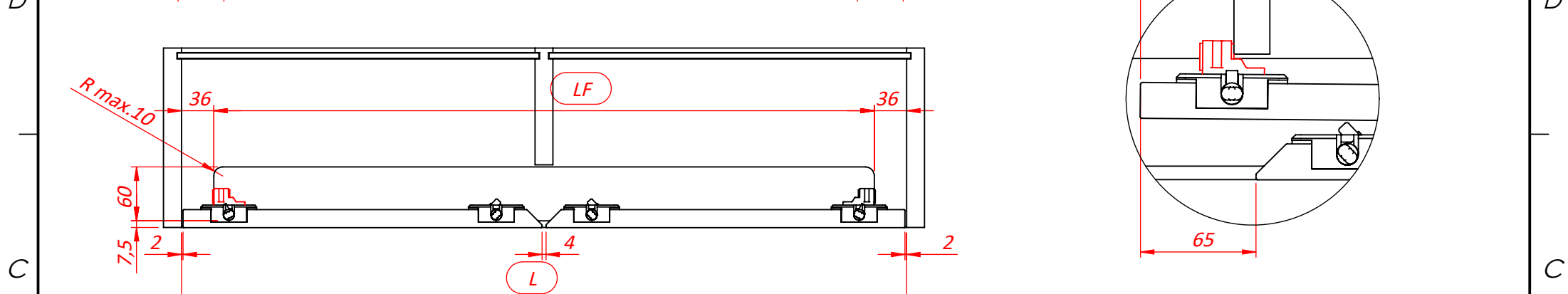
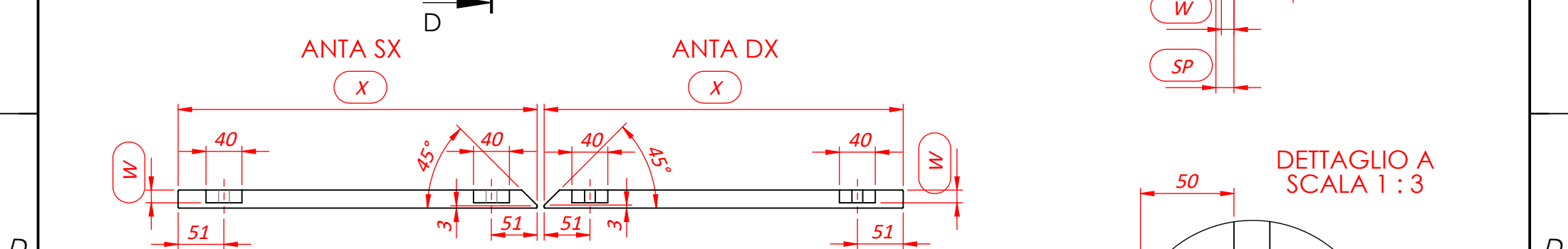
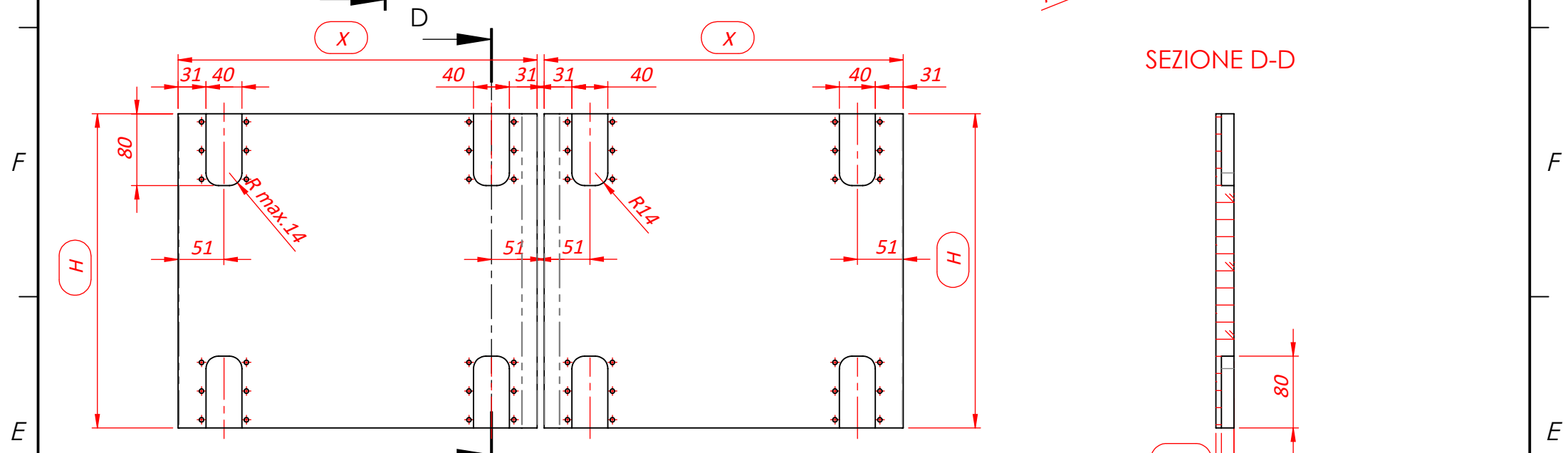
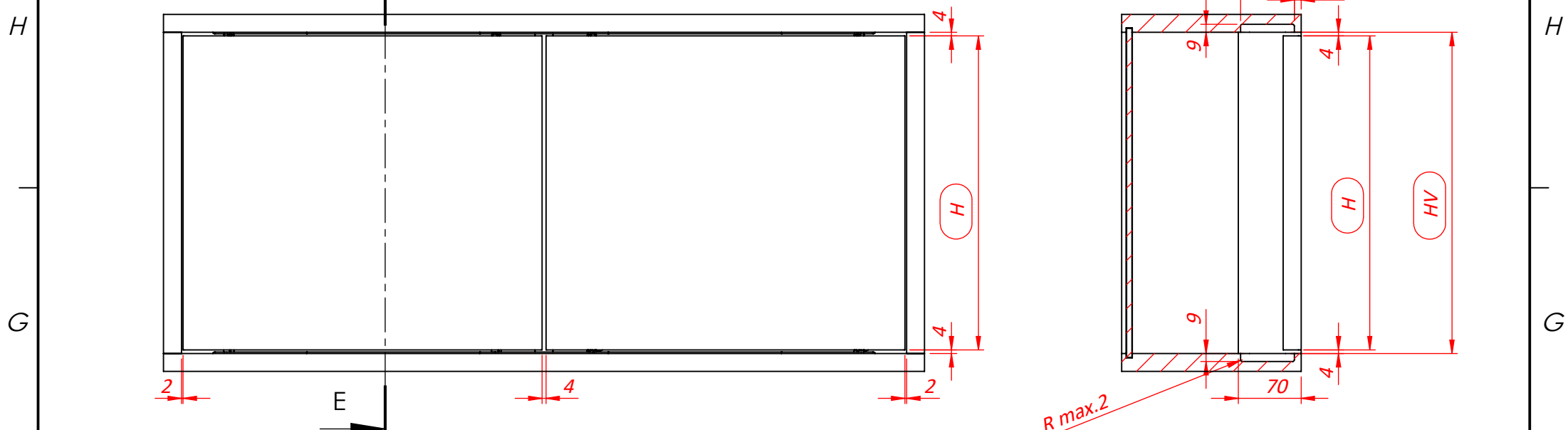

KIT STANDARD	
H	X
Max.1600	Max.900
Max.1600	Max.750
Max.1600	Max.600
Max.1600	Max.450

KIT SPECIAL	
H	X
Max.1600	Max.1000
Max.1600	Max.950
Max.1600	Max.850
Max.1600	Max.800
Max.1600	Max.700
Max.1600	Max.650

FORMULE
H=HV-8
$X=(L-2-4-2)/2$
$L=(X*2)+2+4+2$
$LF=L-(36*2)$

QUOTE FRESATE	
SP=22	W=16
SP=20	W=14
SP=18	W=12

6 5 4 3 2 1

A B C D E F G H